

**Page 2**  
LPC3154 Powering and Unused parts

**Page 3**  
LPC3154 Digital I/O

**Page 4**  
JTAG Interface

**Page 5**  
LPC800 with Expansion connector

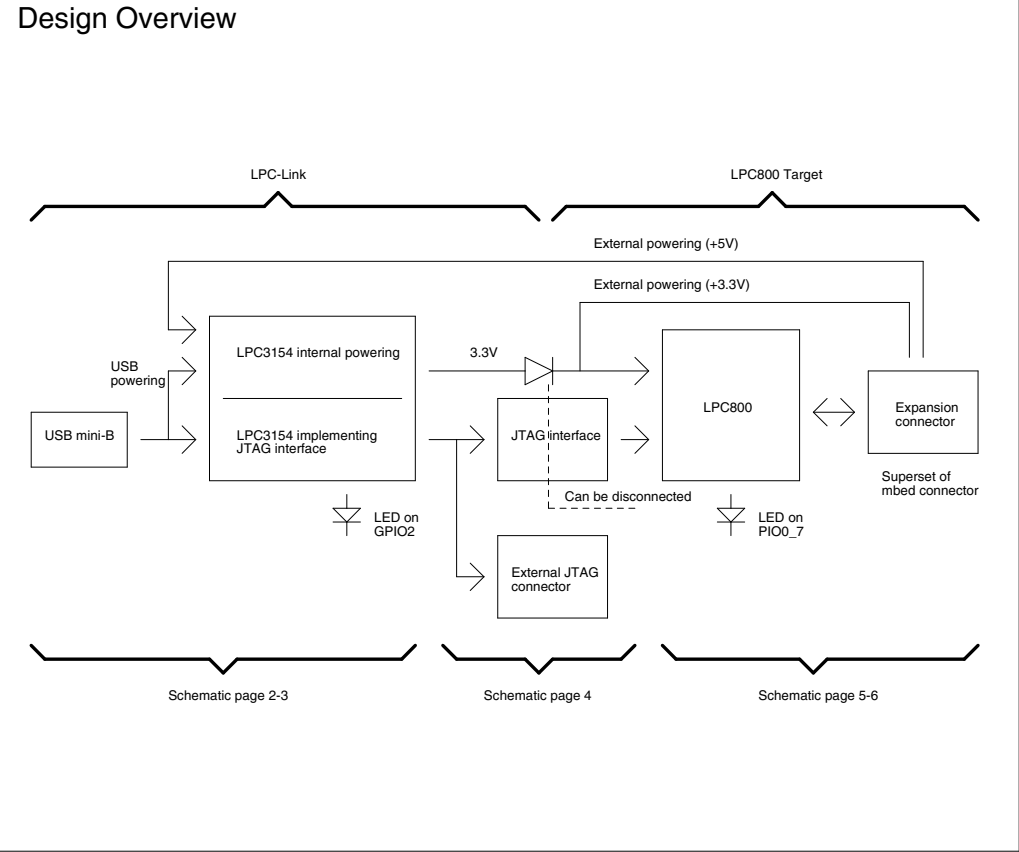

UL = UnLoaded = normally not mounted component.

Default jumper settings are indicated in the schematic.  
However, always check jumper positions on actual boards  
since there is no guarantee that all jumpers are in default place.



© Embedded Artists AB

TITLE: LPCXpresso LPC800 rev A	
Document Number:	
Date: 2012-10-26 11:33:31	Sheet: 1/5



# Boot mode - USB via DFU class

## USB 2.0 OTG Interface

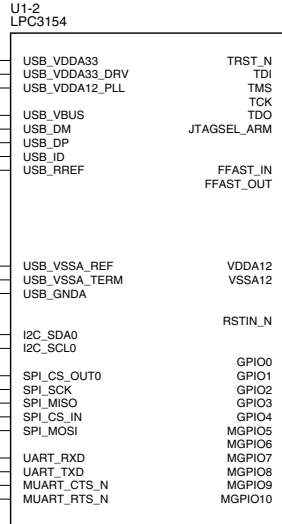
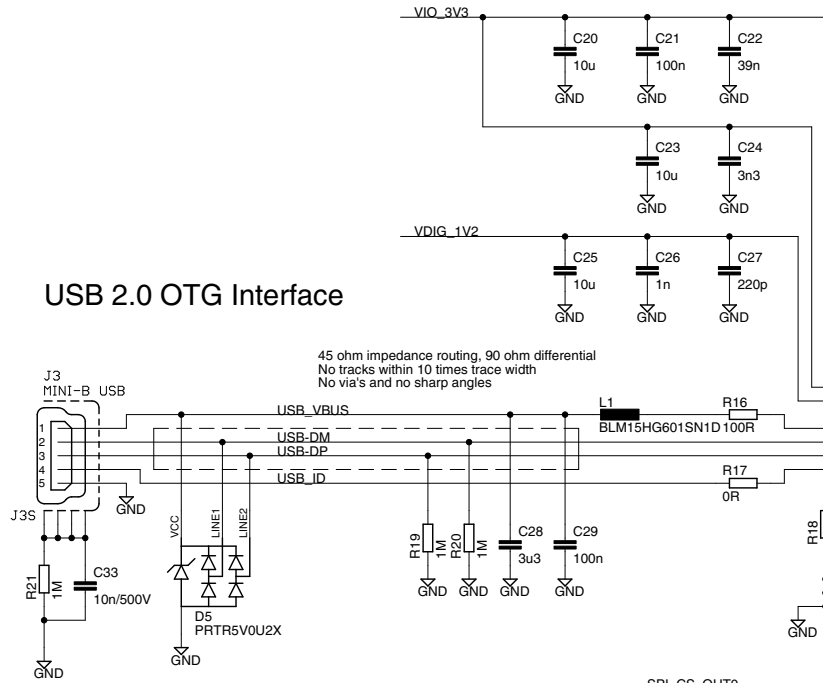

## LED

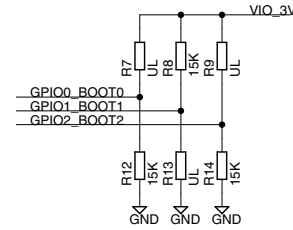
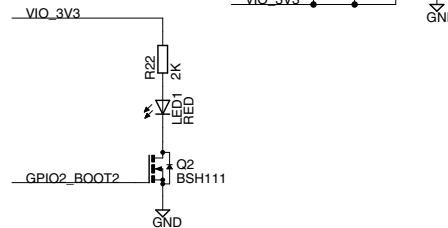

## LPC3154-JTAG

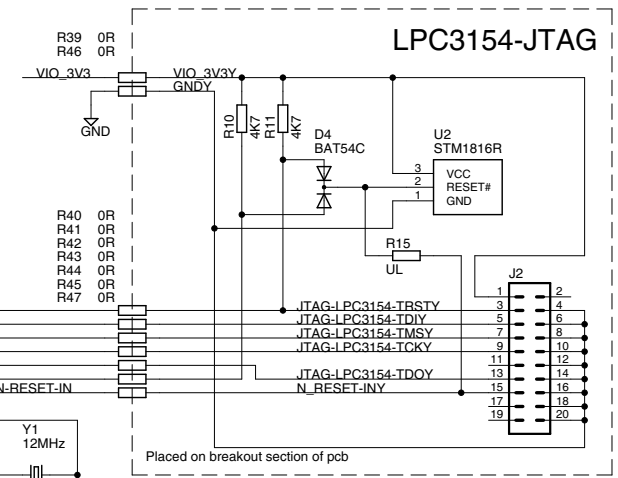

## SPI-FLASH

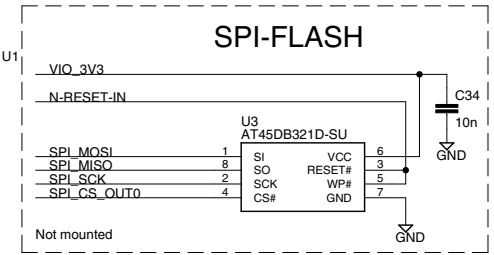

(C) Embedded Artists AB

TITLE: LPCXpresso LPC800 rev A

Document Number:

Date: 2012-10-26 11:33:31

Sheet: 3/5

# SWD/JTAG Interface

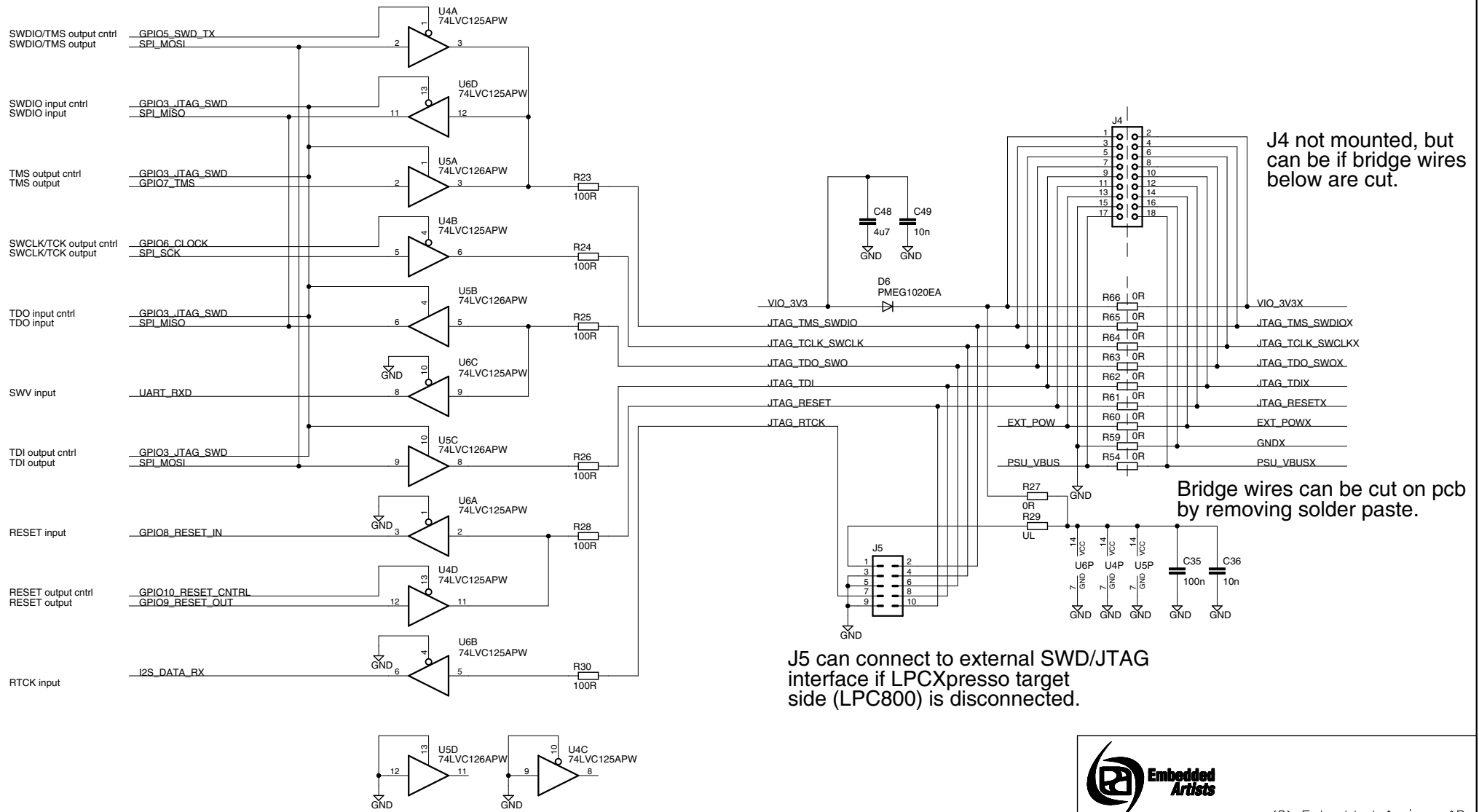

J4 not mounted, but can be if bridge wires below are cut.

Bridge wires can be cut on pcb by removing solder paste.

J5 can connect to external SWD/JTAG interface if LPCXpresso target side (LPC800) is disconnected.



(C) Embedded Artists AB

TITLE: LPCXpresso LPC800 rev A

Document Number:

Date: 2012-10-26 11:33:31

Sheet: 4/5

